



2501 Northchase Pkwy SE
Wilmington, NC 28405

"HH6-PCD" STEEL DOOR w/ SIDELITE OUTSWING "IMPACT"

GENERAL NOTES

1. This product has been evaluated and is in compliance with the 5th Edition (2014) Florida Building Code (FBC) structural requirements including the "High Velocity Hurricane Zone" (HVHZ).
2. Product anchors shall be as listed and spaced as shown on details. Anchor embedment to base material shall be beyond wall dressing or stucco.
3. When used in the "HVHZ" this product complies with Section 1626 of the Florida Building Code and does not require an impact resistant covering.
4. When used in areas outside of the "HVHZ" requiring wind borne debris protection this product complies with Section 1609.1.2 of the FBC and does not require an impact resistant covering. This product meets missile level "D" and includes Wind Zone 4 as defined in ASTM E1996 and Section 1609.1.2.2 of the FBC.
5. Site conditions that deviate from the details of this drawing require further engineering analysis by a licensed engineer or registered architect.
6. This product does not meet the water infiltration requirements for the "HVHZ" and shall be installed only in non-habitable areas or at habitable locations protected by an overhang or canopy such that the angle between the edge of canopy or overhang to sill is less than 45 degrees.
7. All steel shall be protected as specified in Section 2222.6 of the FBC.

TABLE OF CONTENTS

SHEET#	DESCRIPTION
1	Typical elevations, design pressures, & general notes
2	Door panel details
3	Elevation
4	Horizontal and vertical cross sections
5	Horizontal and vertical cross sections
6	Anchoring details
7	Anchoring details
8	Components
9	Bill of materials and components and glazing detail

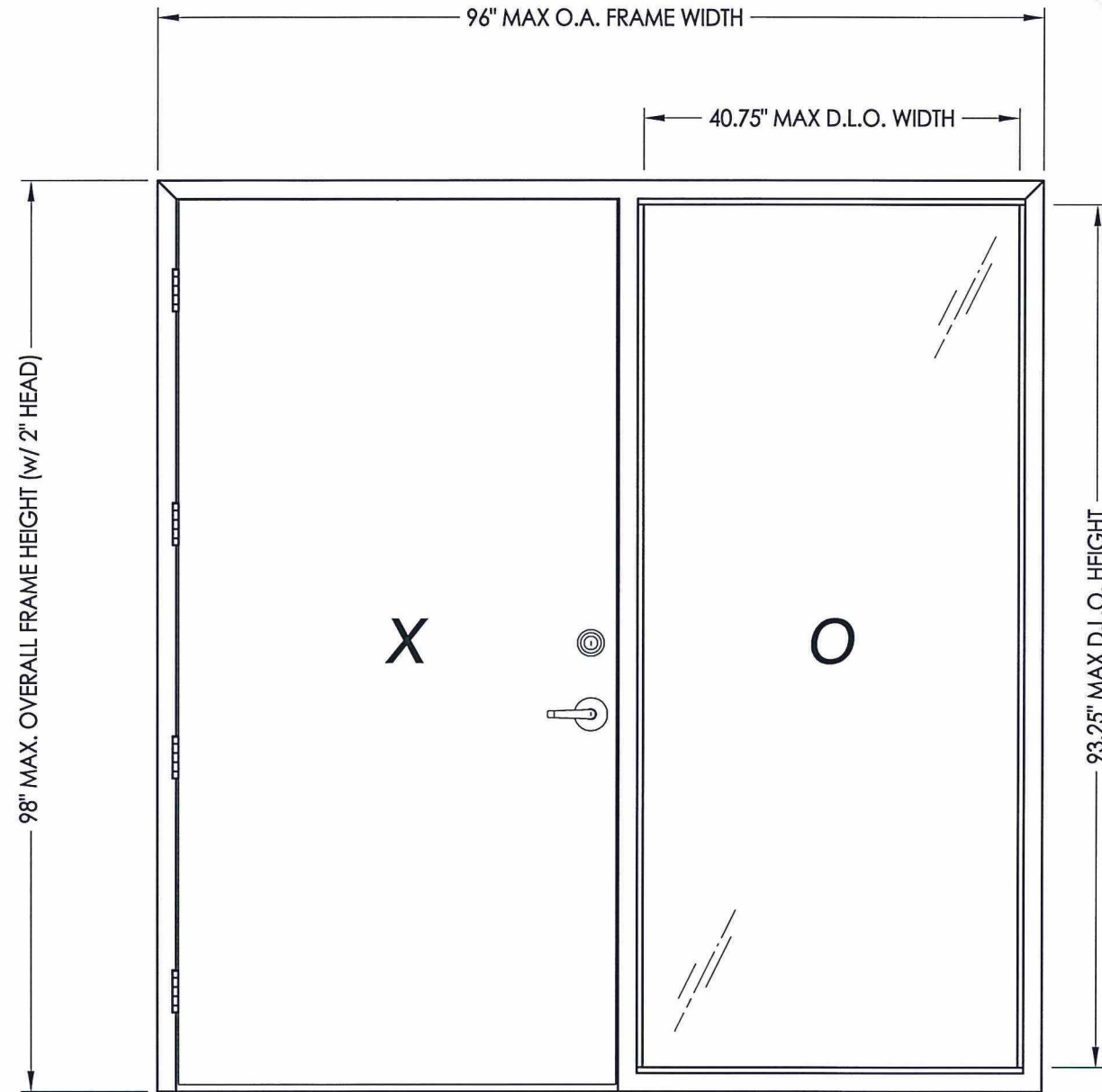

MAX. OVERALL DIMENSION	DESIGN PRESSURE (PSF)	
	POSITIVE	NEGATIVE
96.0" X 98.0"	+65.0	-70.0

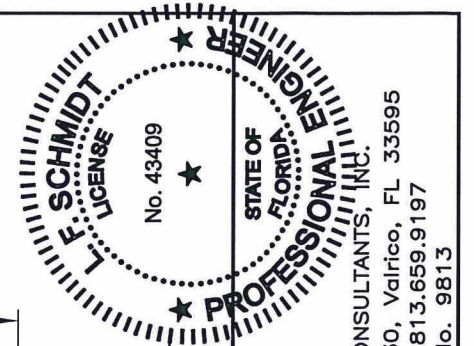

LFS
9.1.15

Documents Prepared By:
Lyndon F. Schmidt
P.E. No. 43409

RW
BUILDING CONSULTANTS, INC.
P.O. Box 230, Vairico, FL 33595
Phone No.: 813.659.9197
FBPE C.A. No. 9813

PRODUCT: HMF EXPRESS

PART OR ASSEMBLY: TYPICAL ELEVATIONS, DESIGN PRESSURES & GENERAL NOTES

NO.	DATE	BY	REVISIONS

DATE: 8/31/15
SCALE: N.T.S.
DWG. BY: JK
CHK. BY: LFS
DRAWING NO.: FL-18506.6
SHEET 1 OF 9

R:\Clients\HMF Express Permanent\EL -C - Drawings\EL XXXX (2014)\FL-18506.5-7.dwg, 2.6

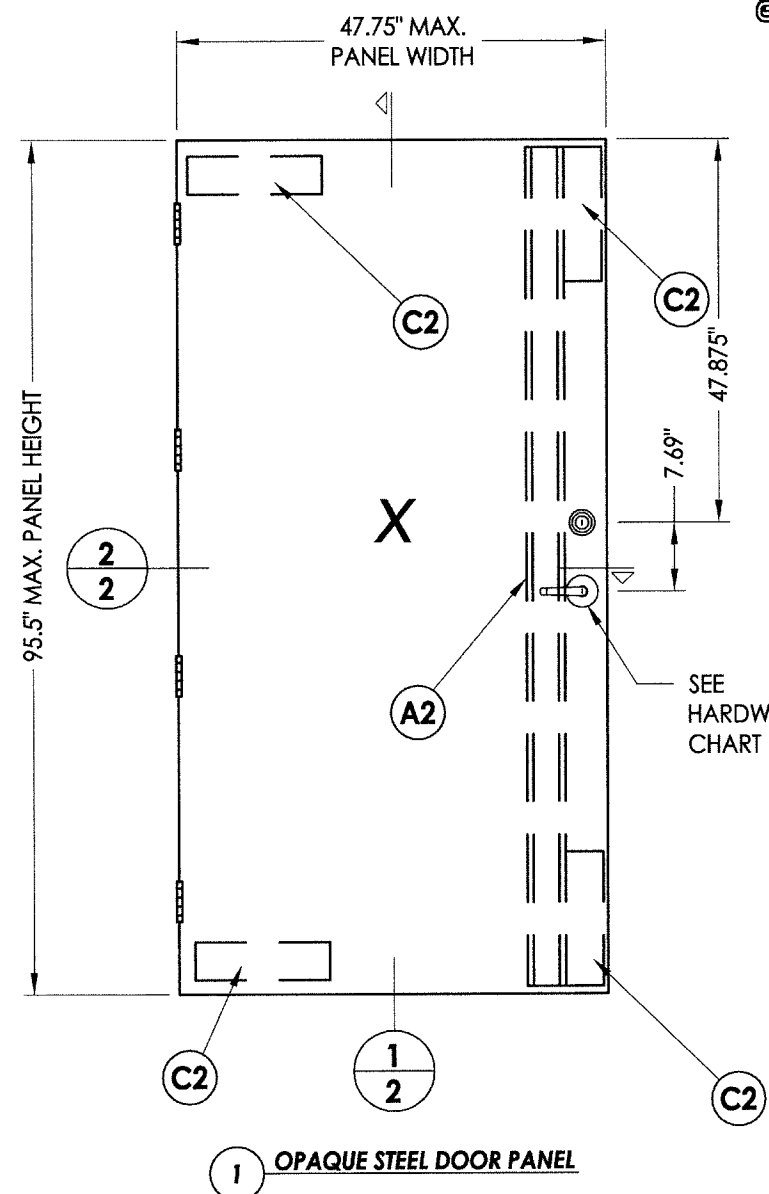

STEEL DOOR SKIN: 16 GA. A60 GALV. (min. 0.058" THK. , Fy = 48,400 psi min.)
 CORE MATERIAL: EPS Foam (Polystyrene - 1.0 PCF Min. Density)

HARDWARE CHART	
MANUFACTURER	MODEL
HAGER	LEVER: 3500 SERIES DEADBOLT: 3200 SERIES

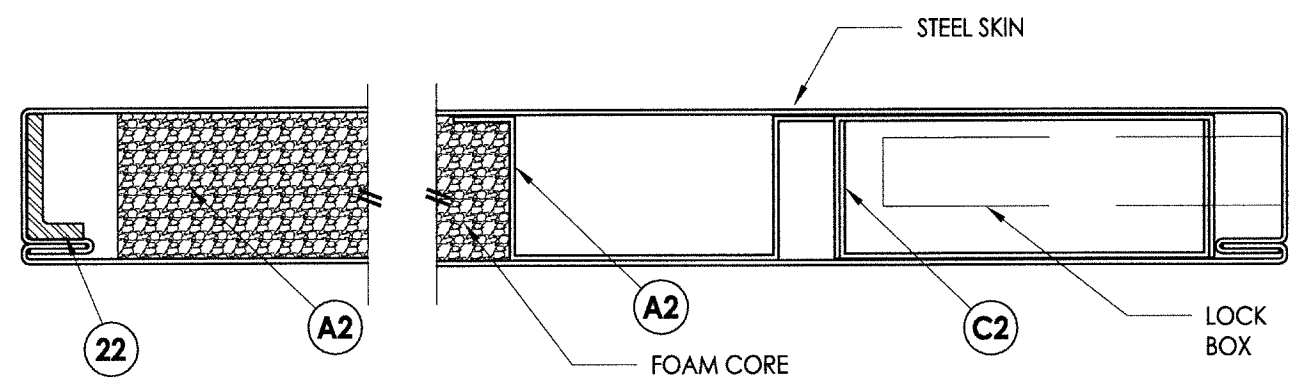

2 HORIZONTAL CROSS SECTION
 2 Door panel

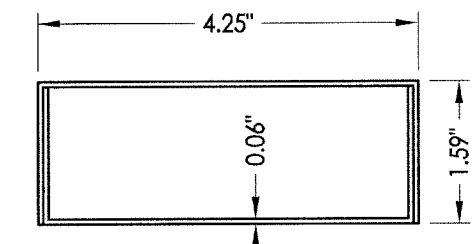

C2 BOX CHANNEL REINFORCEMENT
 A60 Galv. Steel (15" LONG)

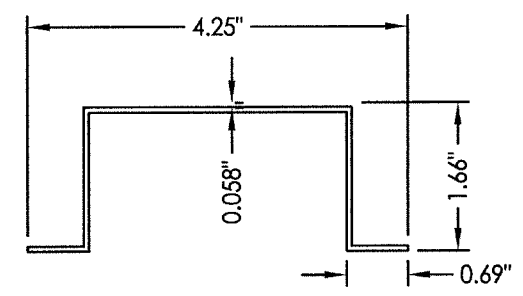

A2 RIB STIFFENER
 A60 Galv. Steel

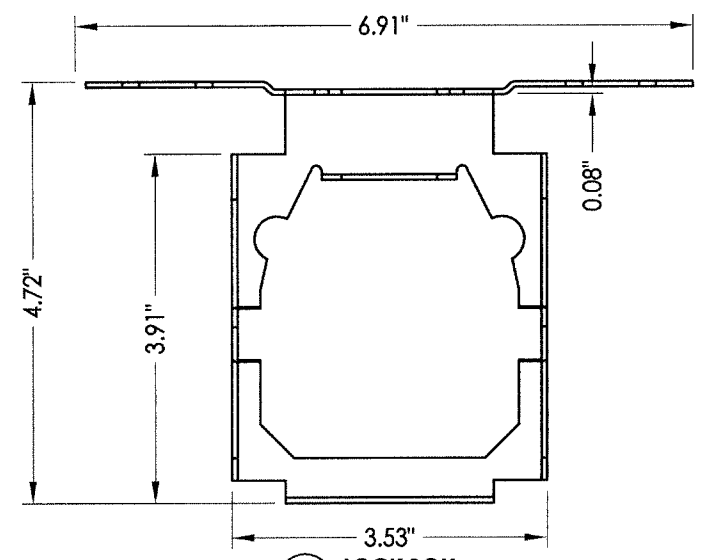

D2 LOCK BOX

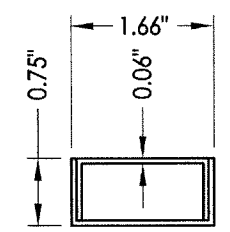

B2 TOP CHANNEL
 A60 Galv. Steel

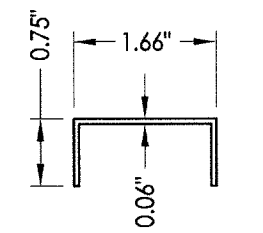

E2 BOTTOM CHANNEL
 A60 Galv. Steel

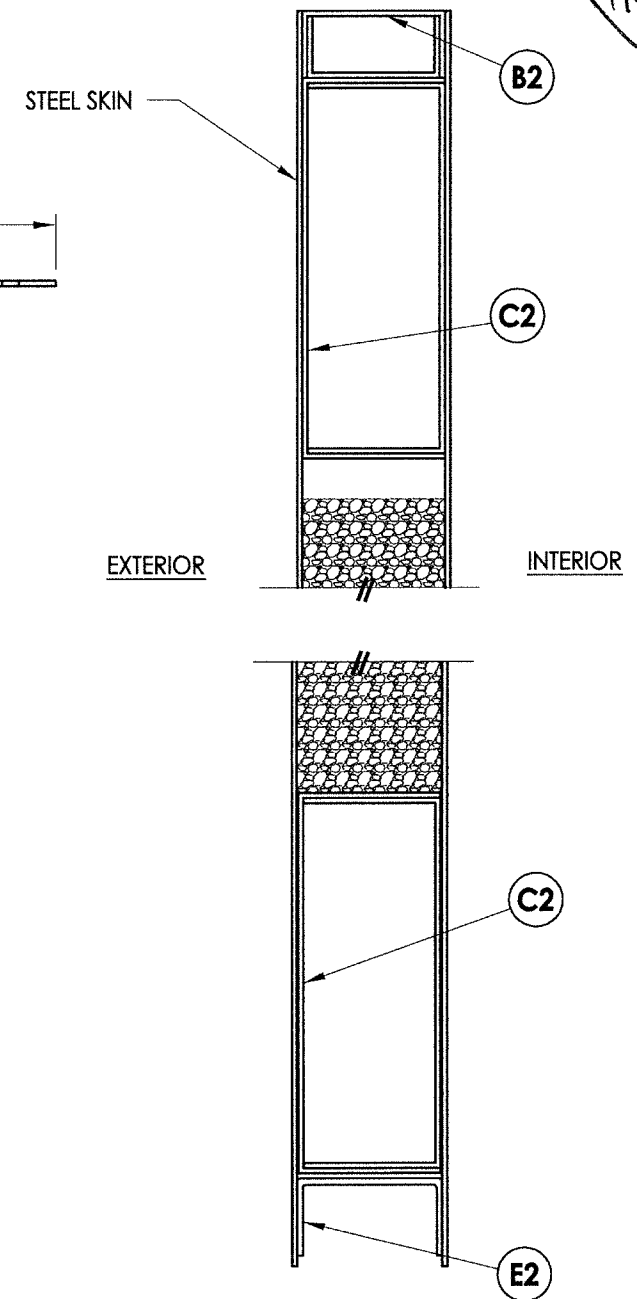

1 VERTICAL CROSS SECTION
 2 Door panel

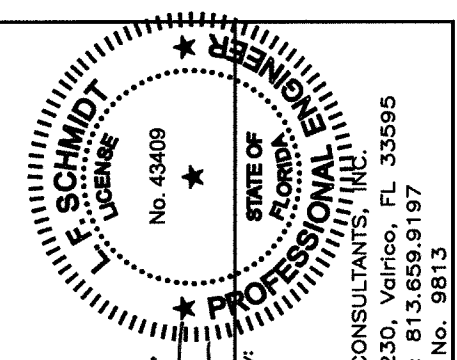

Documents Prepared By:
 Lyndon F. Schmidt
 P.E. No. 43409

R.W. BUILDING CONSULTANTS, INC.
 P.O. Box 230, Valrico, FL 33595
 Phone No.: 813.659.9197
 FBPE C.A. No. 9813

PRODUCT: HMF EXPRESS
 PART OR ASSEMBLY: DOOR PANEL DETAILS

NO.	DATE	BY

DATE: 8/31/15
 SCALE: N.T.S.
 DWG. BY: JK
 CHK. BY: LFS
 DRAWING NO.: FL-18506.6
 SHEET 2 OF 9

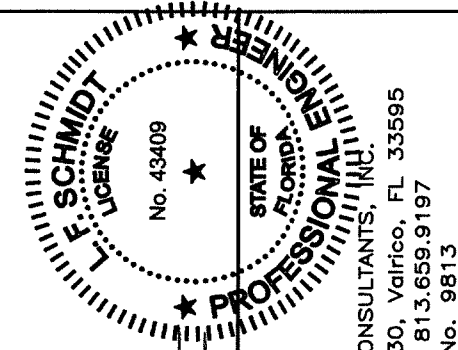
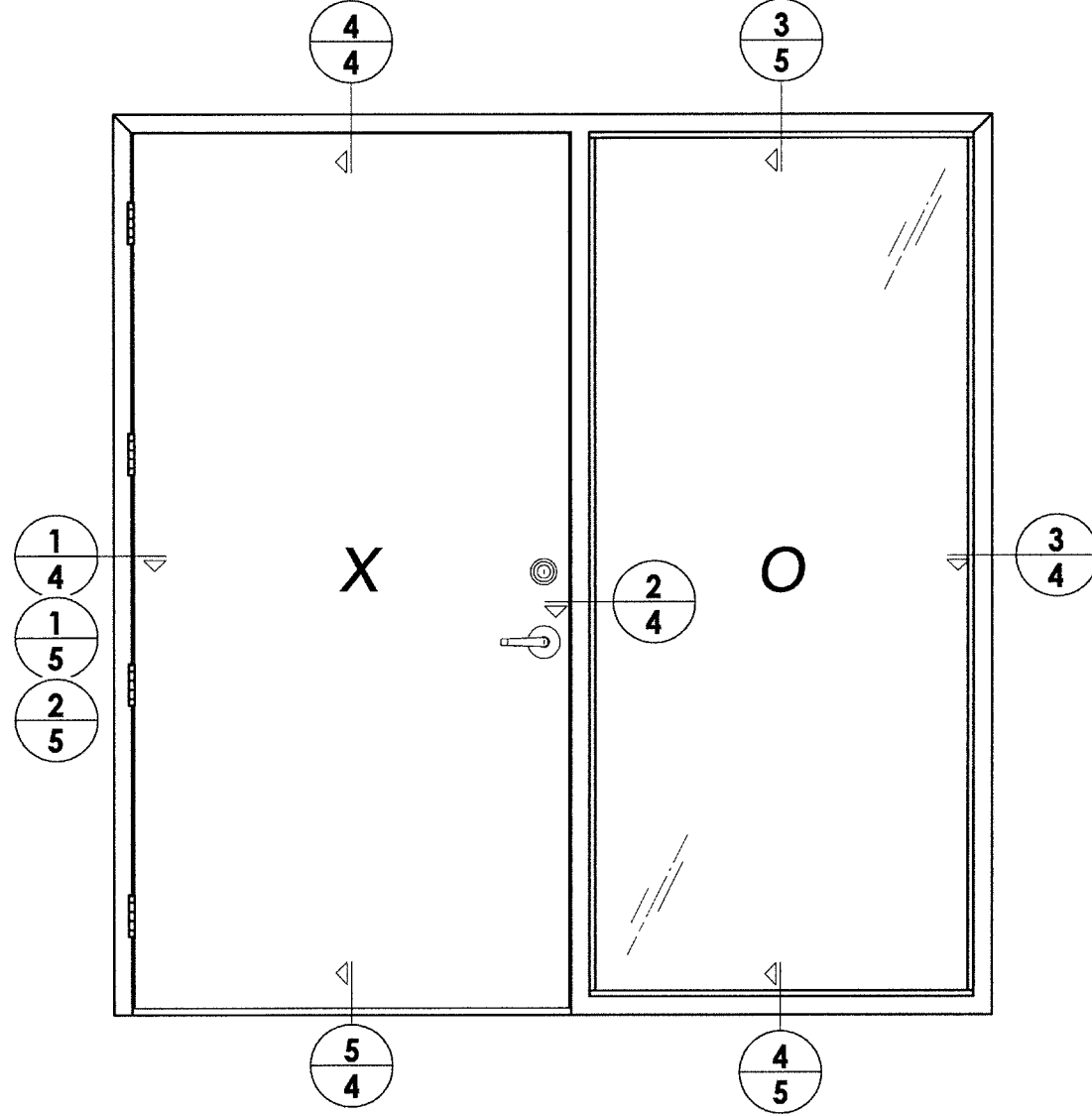

LFS
9.1.15
 Documents Prepared By:
 Lyndon F. Schmidt
 P.E. No. 43409
RW BUILDING CONSULTANTS, INC.
 P.O. Box 230, Vairico, FL 33595
 Phone No.: 813.659.9197
 FBPE C.A. No. 9813

PRODUCT: HMF EXPRESS
 PART OR ASSEMBLY: ELEVATION

NO.	DATE	BY	REVISIONS

DATE: 8/31/15
 SCALE: N.T.S.
 DWG. BY: JK
 CHK. BY: LFS
 DRAWING NO.: FL-18506.6
 SHEET 3 OF 9

R:\Clients\HMF Express PERMANENT\FL - AC - Drawings\FL XXXX (2014)\FL-18506.5-7.dwg, 4.6

- NOTES:
 1. Spot weld anchor bracket to frame:
 2 welds per flange (4 total per bracket).

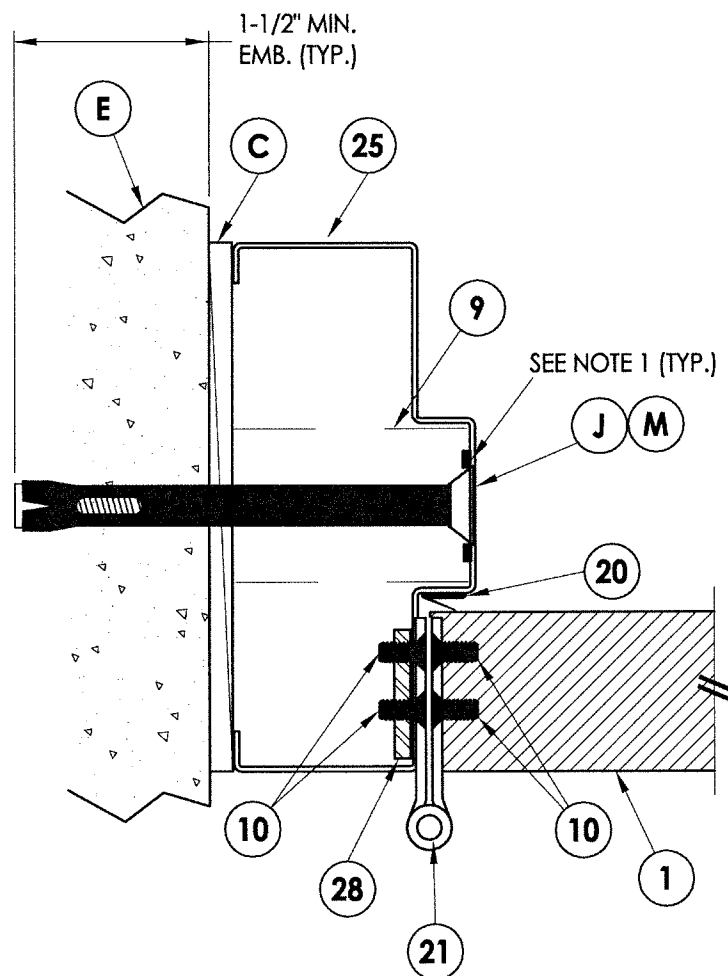

1
4 HORIZONTAL CROSS SECTION

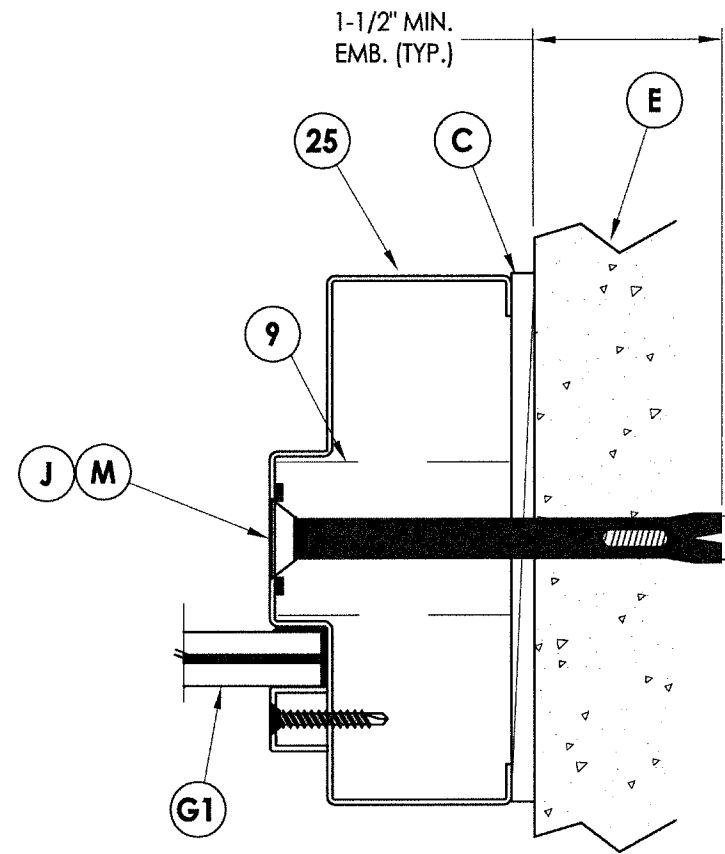

3
4 HORIZONTAL CROSS SECTION

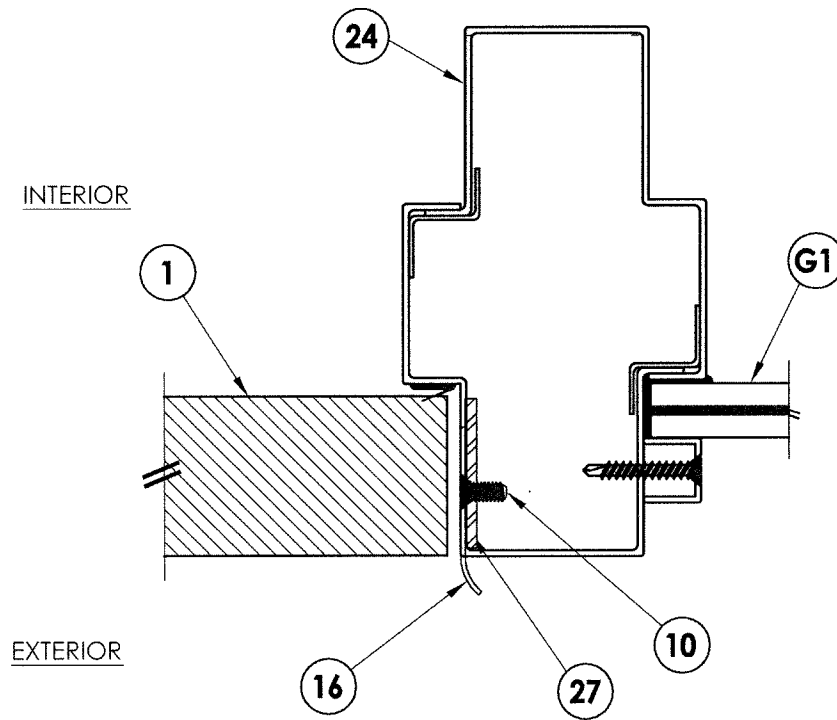

2
4 HORIZONTAL CROSS SECTION

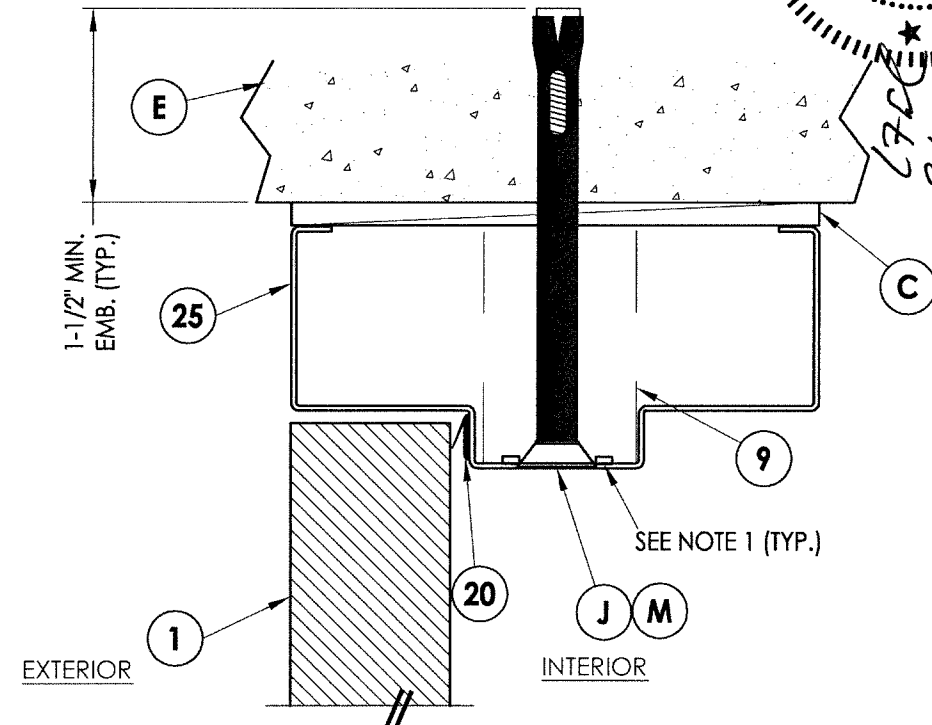

4
4 VERTICAL CROSS SECTION

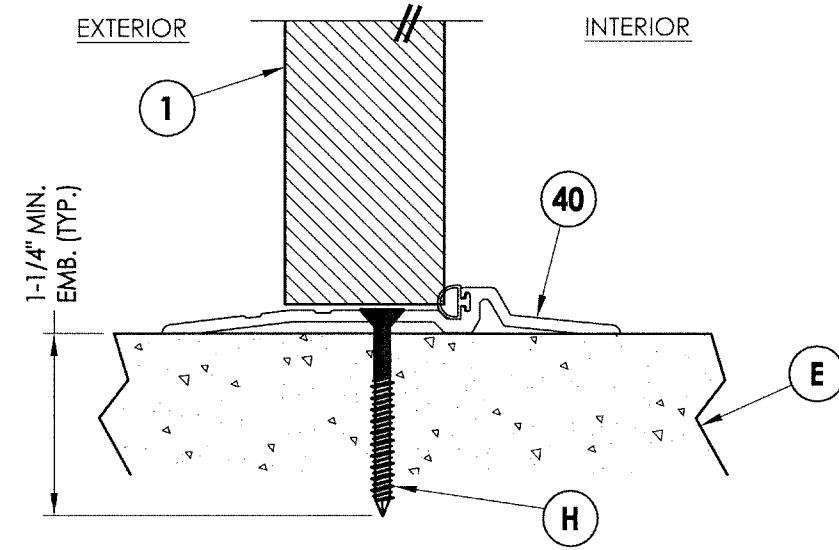

5
4 VERTICAL CROSS SECTION

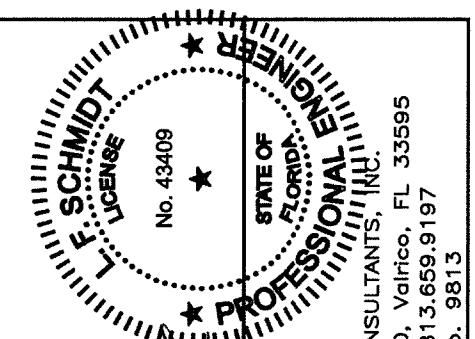

Documents Prepared By:
 Lyndon F. Schmidt
 P.E. No. 43409

R.W. BUILDING CONSULTANTS, INC.
 P.O. Box 230, Valrico, FL 33595
 Phone No.: 813.659.9197
 FBPE C.A. No. 9813

PRODUCT: HMF EXPRESS
 PART OR ASSEMBLY: HORIZONTAL & VERTICAL CROSS SECTIONS

NO.	DATE	BY

DATE: 8/31/15
 SCALE: N.T.S.
 DWG. BY: JK
 CHK. BY: LFS
 DRAWING NO.: FL-18506.6
 SHEET 4 OF 9

R:\Clients\HMF Express PERMANENT\FL -C - Drawings\FL XXXX (2014)\FL-18506.5-7.dwg, 5.6

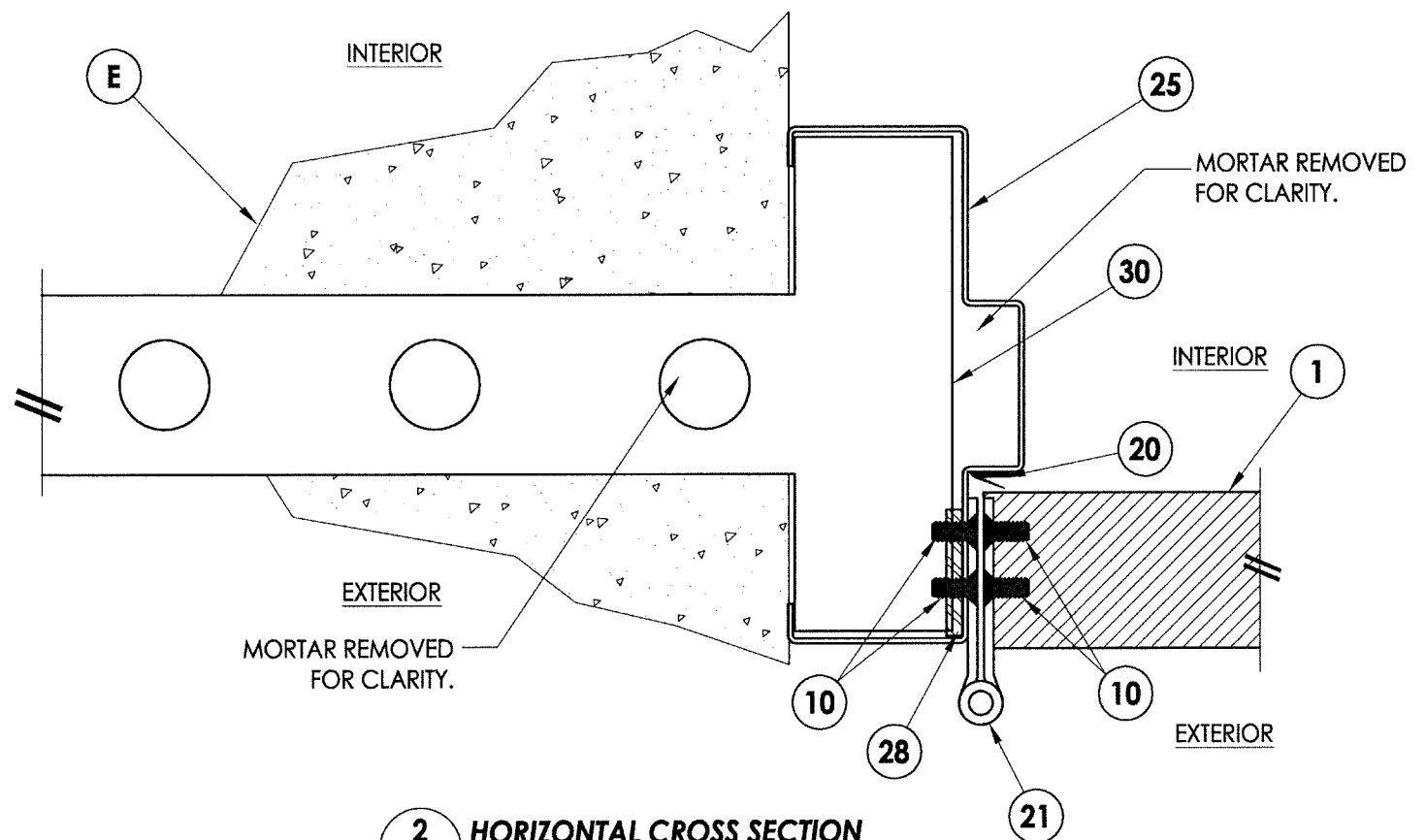

2
5 HORIZONTAL CROSS SECTION

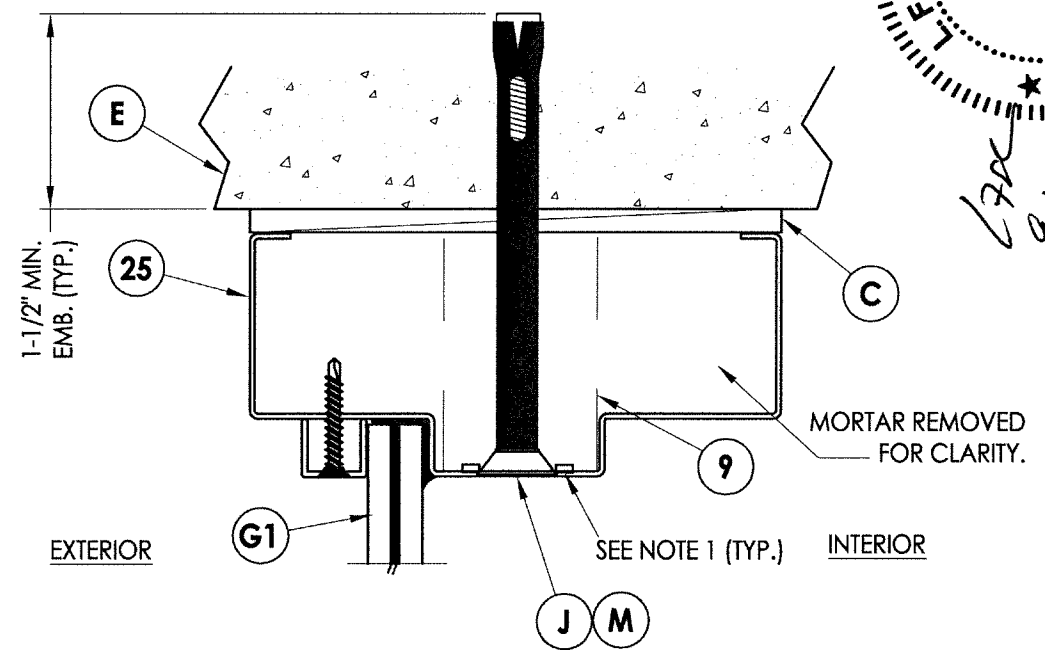

3
5 VERTICAL CROSS SECTION

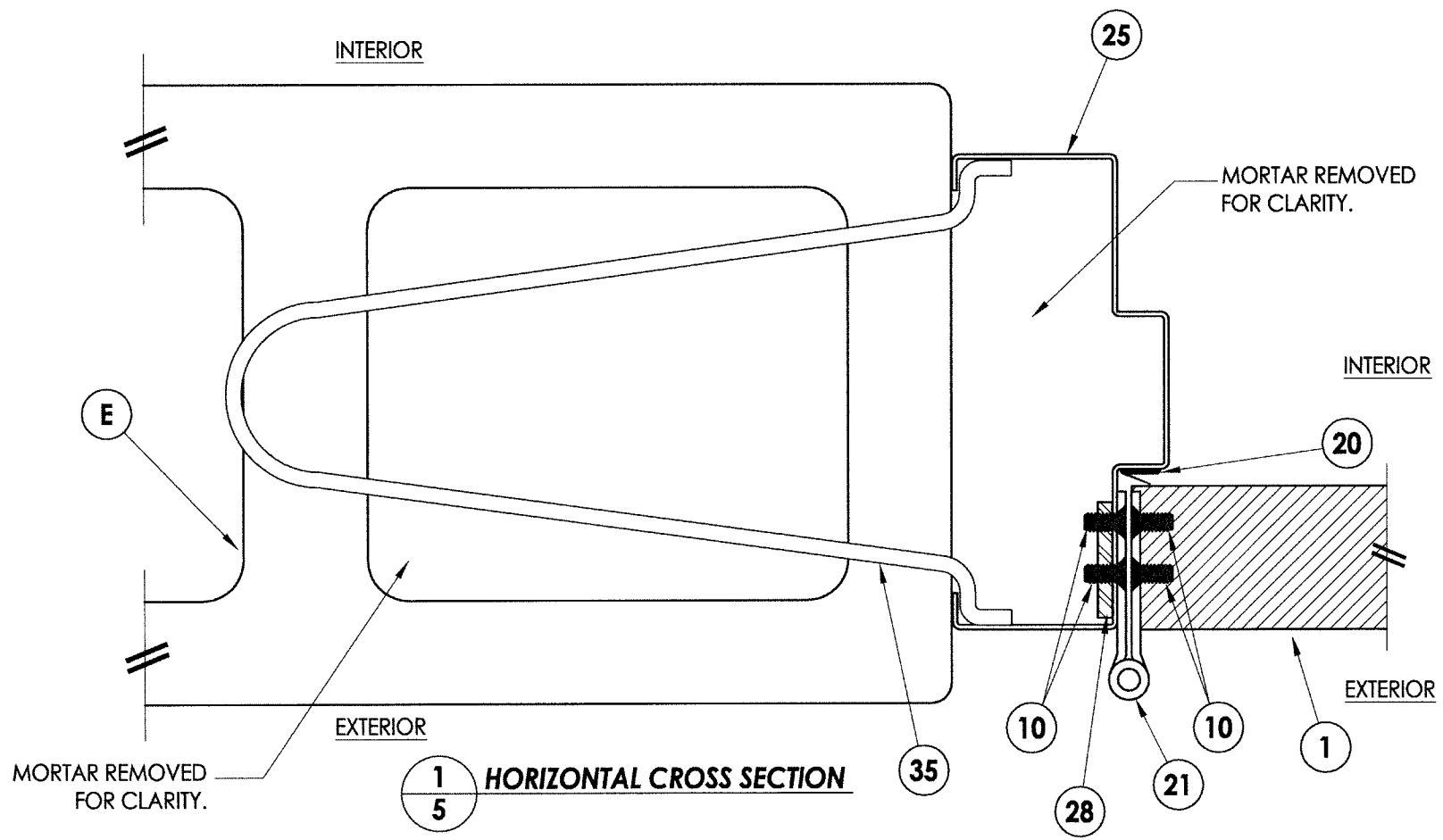

1
5 HORIZONTAL CROSS SECTION

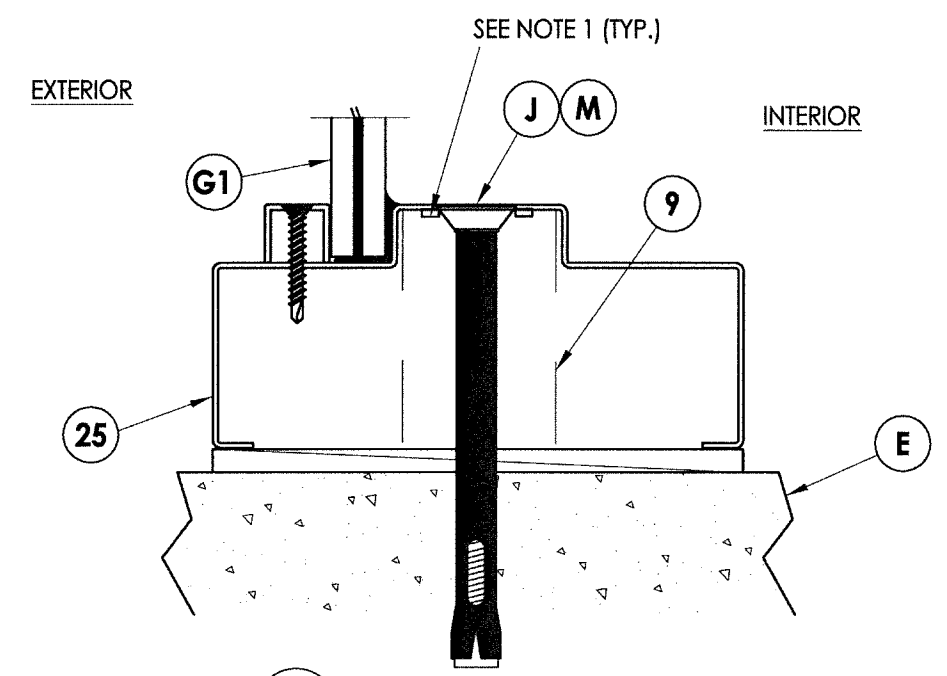

4
5 VERTICAL CROSS SECTION

NOTES:
1. Spot weld anchor bracket to frame:
2 welds per flange (4 total per bracket).

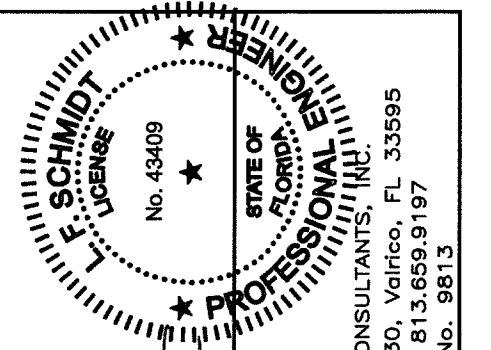

Documents Prepared By:
Lyndon F. Schmidt
P.E. No. 43409
R.W. BUILDING CONSULTANTS, INC.
P.O. Box 230, Valrico, FL 33595
Phone No.: 813.659.9197
FBPE C.A. No. 9813

PRODUCT:	HMF EXPRESS
PART OR ASSEMBLY:	HORIZONTAL & VERTICAL CROSS SECTIONS

NO.	DATE	BY	REVISIONS

DATE:	8/31/15
SCALE:	N.T.S.
DWG. BY:	JK
CHK. BY:	LFS
DRAWING NO.:	FL-18506.6
SHEET	5 OF 9

R:\Clients\HMF Express PERMANENT\FL - AC - Drawings\FL XXXX (2014)\FL-18506.5-7.dwg, 6.6

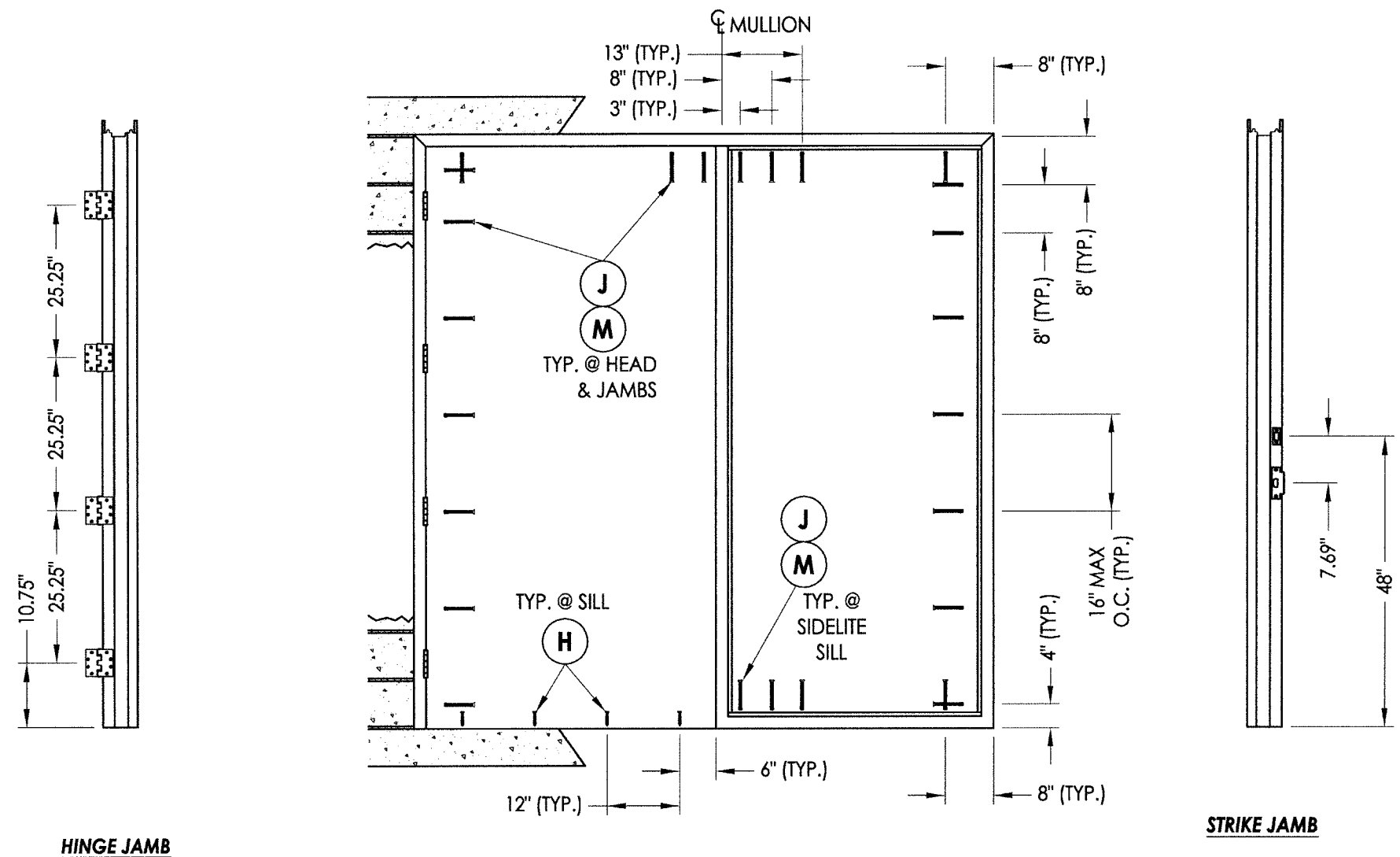

HINGE JAMB

FRAME ANCHORING
Masonry Construction
Concrete Anchors

STRIKE JAMB

CONCRETE ANCHOR NOTES:

- Concrete screw locations may be adjusted to maintain a minimum 1" edge distance to mortar joints. If concrete screw locations noted as "MAX. O.C." must be adjusted to maintain the minimum edge distance to mortar joints, additional concrete screws may be required to ensure the maximum on center dimension is not exceeded.
- Concrete anchor table:

ANCHOR TYPE	ANCHOR LOCATION	ANCHOR SIZE	MANUFACTURER	MIN. EDGE DISTANCE	MIN. EMBEDMENT
CONCRETE ANCHOR SCREW	JAMBS	3/8"	LDT TAPCON® (ITW BUILDEX)	3"	1-1/2"
	SILL	1/4"	TAPCON® (ITW BUILDEX) ULTRACON® (ELCO) CRETE-FLEX® (ELCO) TAPPER+® (POWERS)	2-1/2"	1-1/4"
CONCRETE SLEEVE ANCHOR	JAMBS	3/8"	DYNABOLT SLEEVE ANCHOR® (ITW REDHEAD)	2-1/4"	1-1/2"

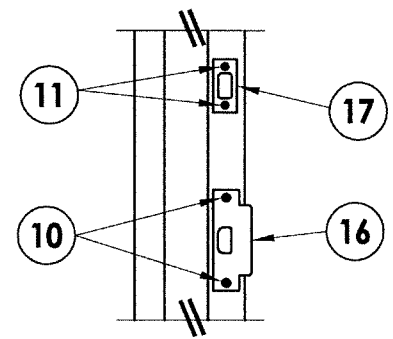

STRIKE DETAIL

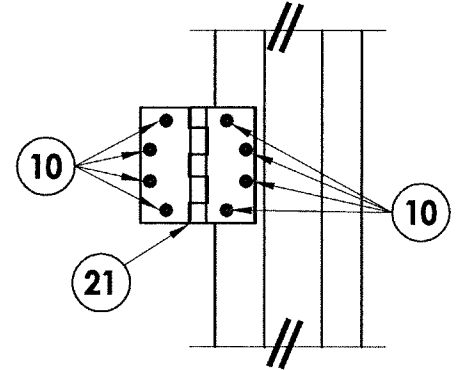

HINGE DETAIL

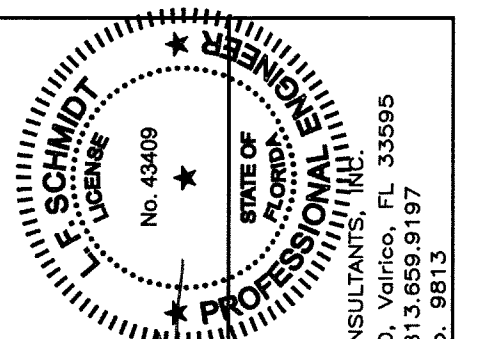

Documents Prepared By:
Lyndon F. Schmidt
P.E. No. 43409

RW BUILDING CONSULTANTS, INC.
P.O. Box 230, Valrico, FL 33595
Phone No.: 813.659.9197
FBPE C.A. No. 9813

PRODUCT: HMF EXPRESS

PART OR ASSEMBLY: ANCHORING DETAILS

NO.	DATE	BY	REVISIONS

DATE: 8/31/15
SCALE: N.T.S.
DWG. BY: JK
CHK. BY: LFS
DRAWING NO.: FL-18506.6
SHEET 6 OF 9

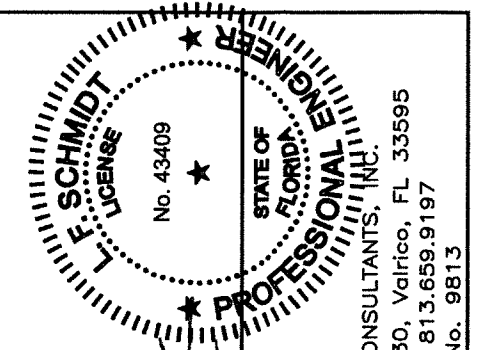
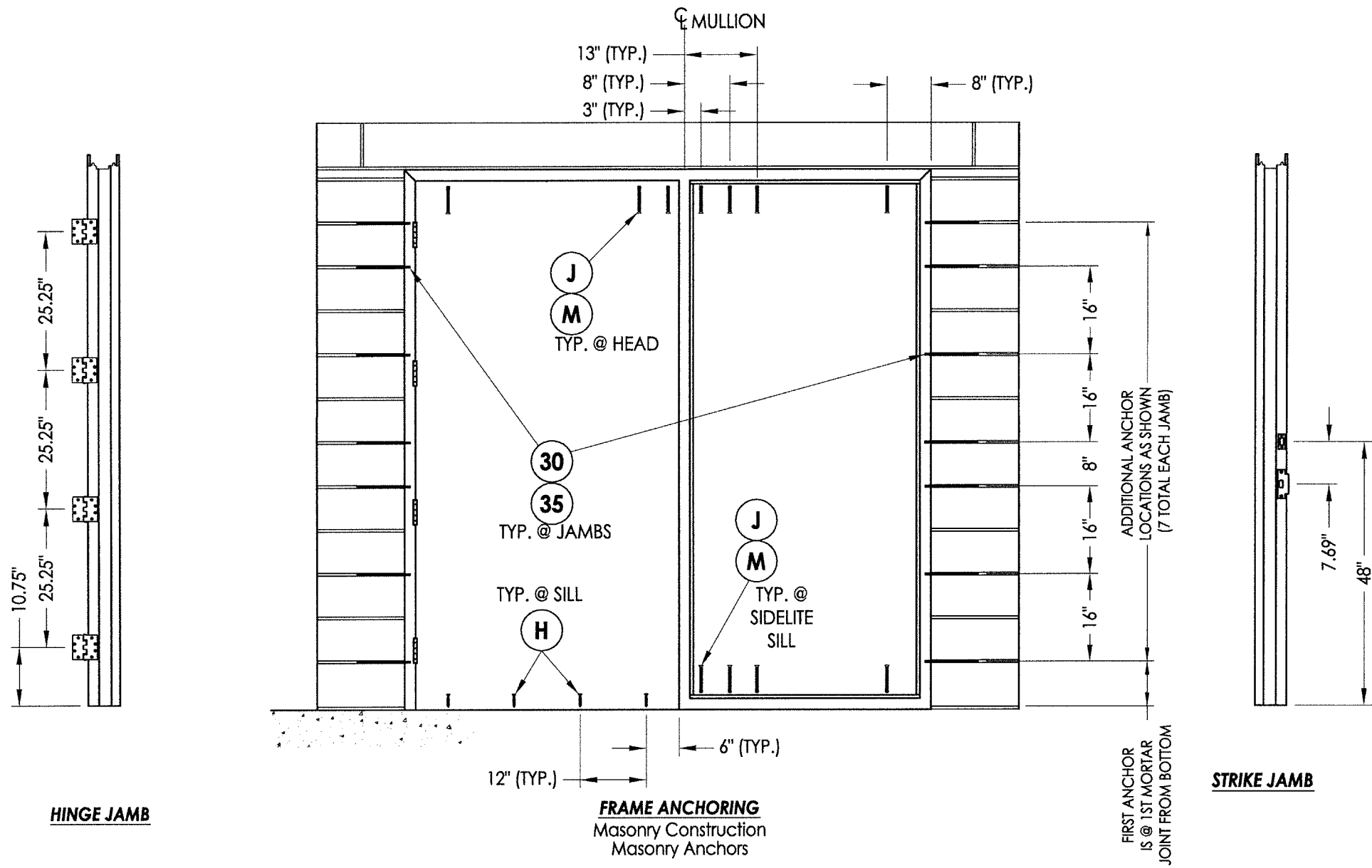

Documents Prepared By:
Lyndon F. Schmidt
P.E. No. 43409

R.W. BUILDING CONSULTANTS, INC.
P.O. Box 230, Valrico, FL 33595
Phone No.: 813.659.9197
FBPE C.A. No. 9813

PRODUCT: HMF EXPRESS
PART OR ASSEMBLY: ANCHORING DETAILS

NO.	DATE	BY	REVISIONS

DATE: 8/31/15
SCALE: N.T.S.
DWG. BY: JK
CHK. BY: LFS
DRAWING NO.: FL-18506.6
SHEET 7 OF 9

CONCRETE ANCHOR NOTES:

- Concrete screw locations may be adjusted to maintain a minimum 1" edge distance to mortar joints. If concrete screw locations noted as "MAX. O.C." must be adjusted to maintain the minimum edge distance to mortar joints, additional concrete screws may be required to ensure the maximum on center dimension is not exceeded.
- Concrete anchor table:

ANCHOR TYPE	ANCHOR LOCATION	ANCHOR SIZE	MANUFACTURER	MIN. EDGE DISTANCE	MIN. EMBEDMENT
CONCRETE ANCHOR SCREW	JAMBS	3/8"	LDT TAPCON® (ITW BUILDEX)	3"	1-1/2"
	SILL	1/4"	TAPCON® (ITW BUILDEX) ULTRACON® (ELCO) CRETE-FLEX® (ELCO) TAPPER+® (POWERS)	2-1/2"	1-1/4"
	JAMBS	3/8"	DYNABOLT SLEEVE ANCHOR® (ITW REDHEAD)	2-1/4"	1-1/2"

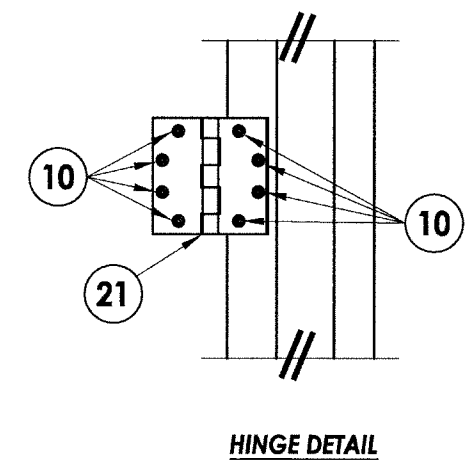
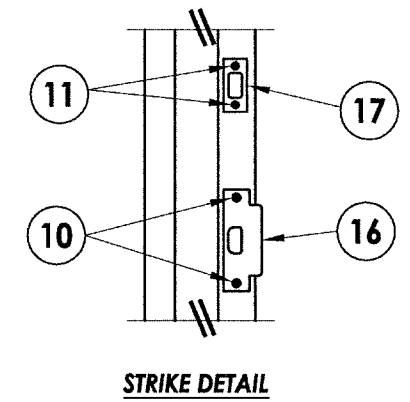

R:\Clients\HMF Express Permanent\FL -C - Drawings\FL XXXX (2014)\FL-18506.5-7.dwg, 8.6

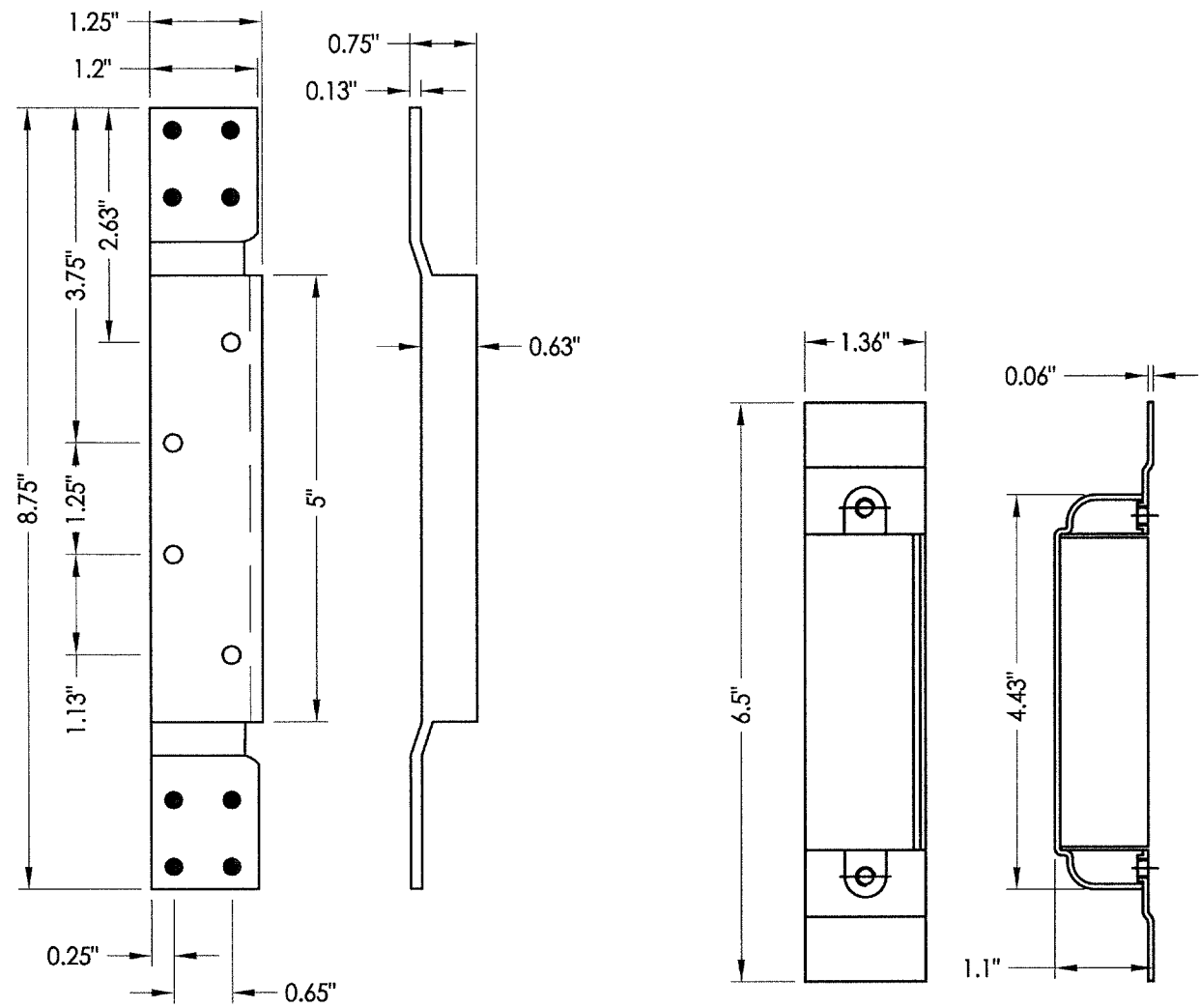

22 DOOR HINGE REINFORCEMENT

8 DUST BOX

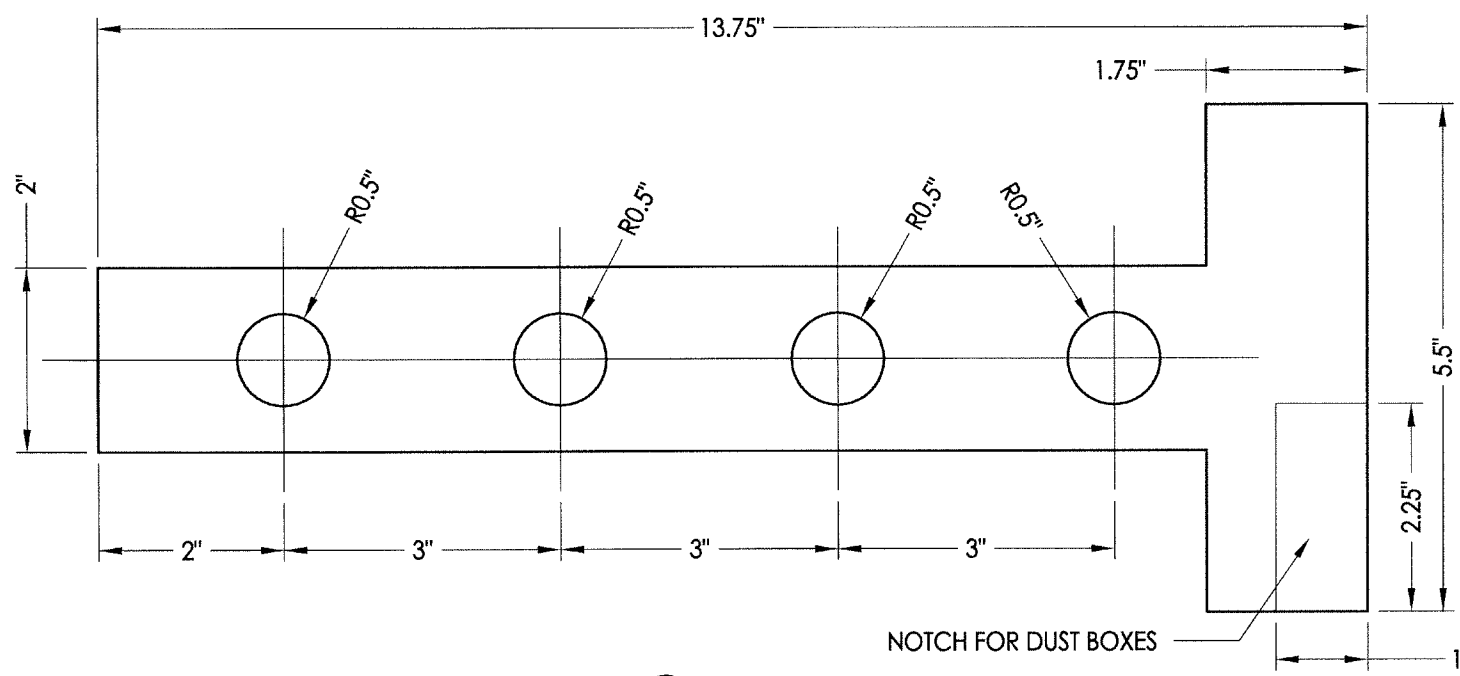

30 T ANCHOR
0.056\"/>

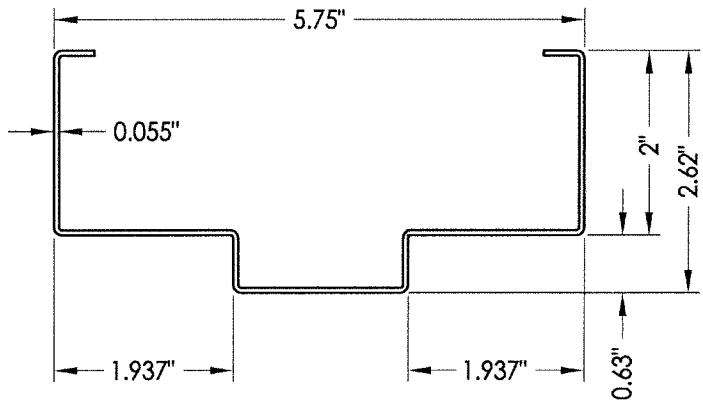

25 HOLLOW METAL FRAME
2\"/>

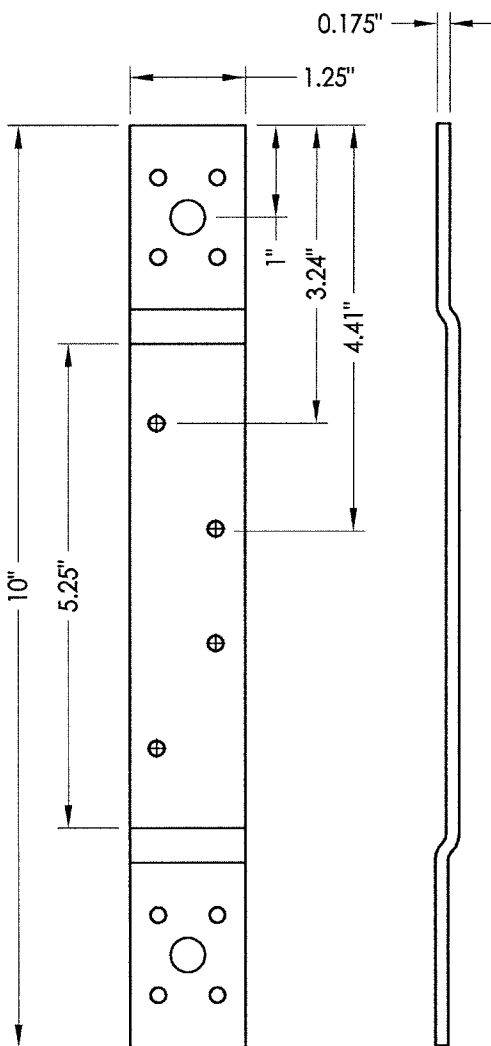

28 FRAME HINGE REINFORCEMENT

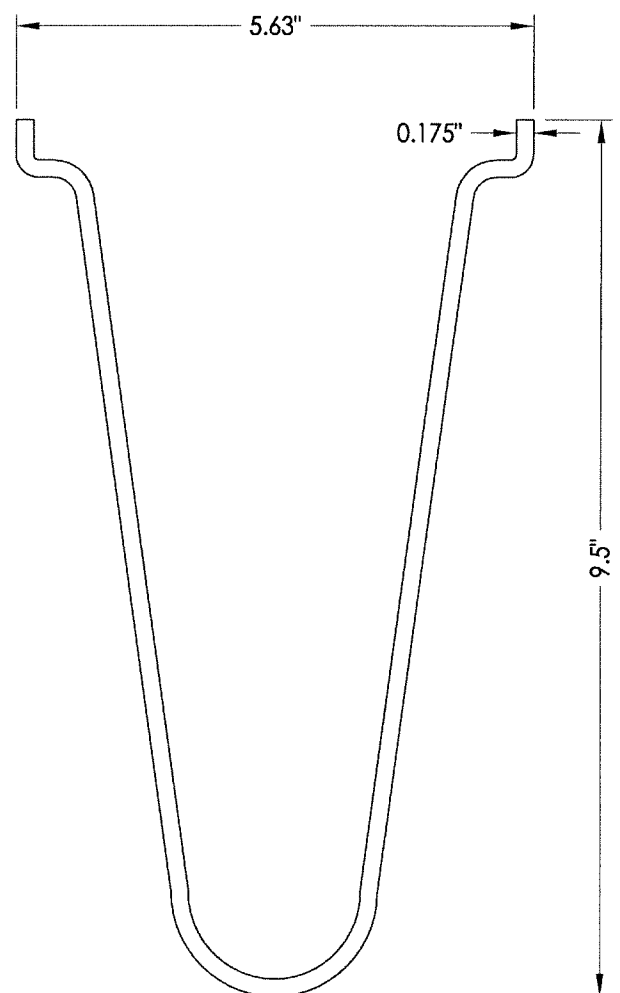

35 WIRE ANCHOR

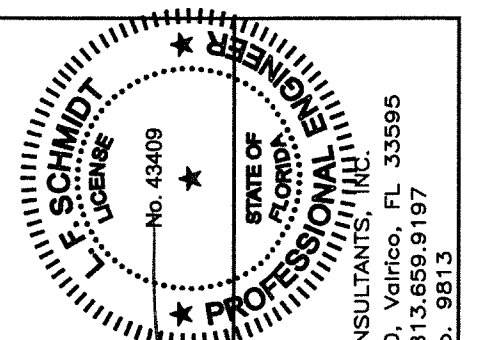

Documents Prepared By:
Lyndon F. Schmidt
P.E. No. 43409
R.W. BUILDING CONSULTANTS, INC.
P.O. Box 230, Valrico, FL 33595
Phone No.: 813.659.9197
FBPE C.A. No. 9813

PRODUCT:		HMF EXPRESS	
PART OR ASSEMBLY:		COMPONENTS	
NO.	DATE	BY	REVISIONS

DATE:	8/31/15
SCALE:	N.T.S.
DWG. BY:	JK
CHK. BY:	LFS
DRAWING NO.:	FL-18506.6
SHEET	8 OF 9

R:\Clients\HMF Express PERMANENT\FL - C - Drawings\FL_XXXX (2014)\FL-18506.5-7.dwg, 9.6

BILL OF MATERIALS		
ITEM #	DESCRIPTION	MATERIAL
C	1/4" MAX. SHIM SPACE	-
D	1/4" X 2-3/4" ELCO OR ITW CONCRETE SCREW	STEEL
E	MASONRY - 3,000 PSI MIN. CONCRETE CONFORMING TO ACI 301 OR HOLLOW BLOCK (GROUT FILLED) CONFORMING TO ASTM C90	CONCRETE
H	1/4" X 1-3/4" PFH CONCRETE SCREW (SEE CONCRETE ANCHOR TABLE)	STEEL
J	3/8" X 5" PFH DYNABOLT SLEEVE ANCHOR (SEE CONCRETE ANCHOR TABLE)	STEEL
M	3/8" X 5" LDT TAPCON CONCRETE SCREW (SEE CONCRETE ANCHOR TABLE)	STEEL
1	STEEL DOOR PANEL	-
2	GLAZING BEAD	STEEL
3	#6 X 1-1/4" PFH SELF-DRILLING TEK SCREW	STEEL
8	DUST BOX	STEEL
9	ANCHOR BRACKET	STEEL
10	#12-24 X 1/2" PFH MACHINE SCREW	STEEL
11	#8 x 3/4" COMBINATION WOOD/MACHINE SCREW	STEEL
16	ANSI LATCH STRIKE	STEEL
17	DEADBOLT STRIKE	STEEL
19	DEADBOLT STRIKE REINFORCEMENT	STEEL
20	WEATHERSTRIP (HAGER #720)	NEOPRENE
21	4-1/2" X 4-1/2" X 0.125" HINGE	STEEL
22	DOOR HINGE REINFORCEMENT	STEEL
24	MULLION - 16GA (0.055" THK)	STEEL
25	HOLLOW FRAME (2" JAMB) - 16GA (0.055" THK)	STEEL
26	HOLLOW FRAME (2" HEAD) - 16GA (0.055" THK)	STEEL
28	FRAME HINGE REINFORCEMENT	STEEL
30	MASONRY 'T' ANCHOR	STEEL
35	WIRE ANCHOR	STEEL
40	THRESHOLD (HAGER #520S)	ALUMINUM

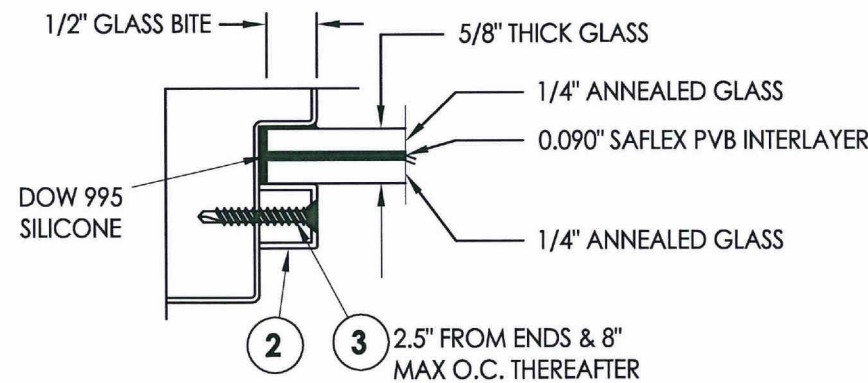

2.5" FROM ENDS & 8" MAX O.C. THEREAFTER

G1 GLAZING DETAIL

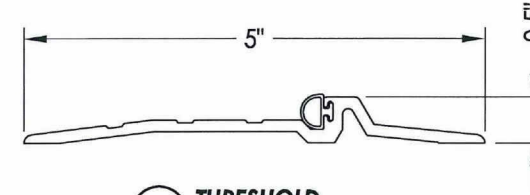

40 THRESHOLD

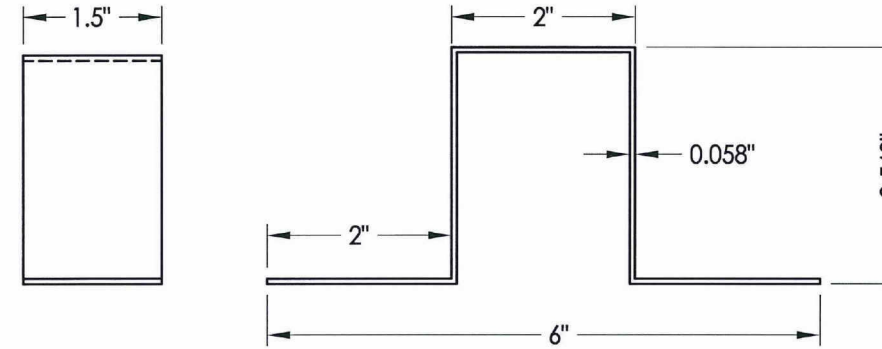

9 ANCHOR BRACKET

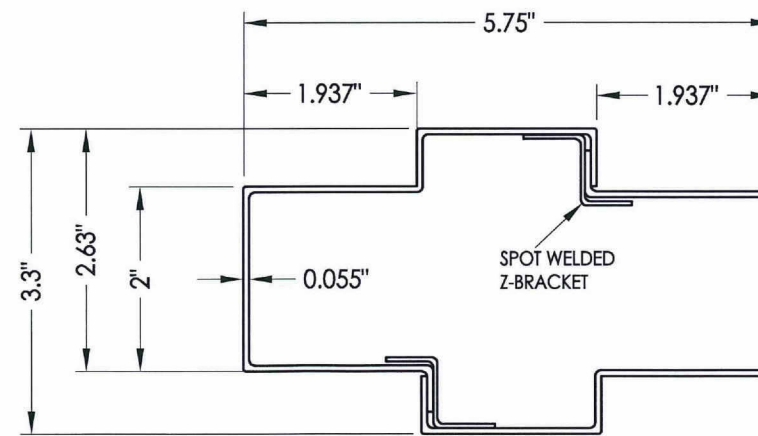

24 MULLION

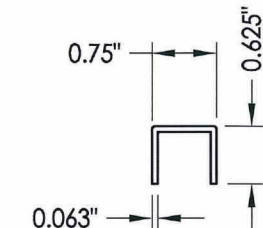

2 GLAZING BEAD

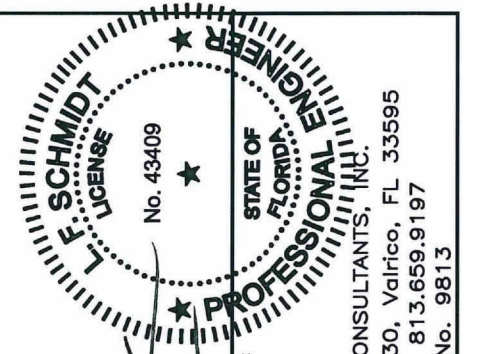

Documents Prepared By:
Lyndon F. Schmidt
P.E. No. 43409

R.W. BUILDING CONSULTANTS, INC.
P.O. Box 230, Valrico, FL 33595
Phone No.: 813.659.9197
FBPE C.A. No. 9813

PRODUCT: HMF EXPRESS

PART OR ASSEMBLY: BILL OF MATERIALS, COMPONENTS & GLAZING, DETAIL

NO.	DATE	BY

DATE: 8/31/15
SCALE: N.T.S.
DWG. BY: JK
CHK. BY: LFS
DRAWING NO.: FL-18506.6
SHEET 9 OF 9